

UNSIGNED HARDCOPY  
NOT CONTROLLED



Instruction  
Hardware Engineering

No. LMS 1-4

**SUBJECT:** Modification of Printed Wiring, Multilayer, or Multiwire Assemblies

**APPROVED BY** Manager, Hardware Engineering

**STATUS** Maintenance Revision

**PURPOSE** Describe the modification procedures that are acceptable for modifying printed wiring, multilayer, or multiwire assemblies. Modification to released printed wiring, multilayer, or multiwire assemblies shall only be performed via an approved Engineering Change Notice (ECN) containing modification instructions or referencing separate modification instructions. Written authorization of the Government acquiring activity or its designated representative may be required if assembly is baselined. This work instruction shall be used by L-3 Communications Corporation, Link Simulation & Training Division (hereafter referred to as Link) personnel when modifying printed wiring, multilayer, or multiwire assemblies.

**AFFECTED FUNCTIONS** Hardware Engineering  
Manufacturing

**REFERENCES** **LMS 4-1** Printed Wiring Board Assembly  
**LMS 4-3** Electrostatic Discharge Sensitive (ESDS) Devices  
**LMS 11-3** Hand Soldering, Electrical

**DEFINITIONS** Circuit card assembly. Consists of a printed wiring board upon which are mounted separately manufactured electronic components, such as capacitors, inductors, resistors, etc. It may also include printed electronic components.

Land. A portion of a conductive pattern that is usually used for making electrical connections, for component attachment, or both.

Modification. The change in the functional characteristics of a product in order to satisfy new acceptance criteria requirements.

Repair. The act of restoring the functional characteristics of a defective product without necessarily restoring the appearance or compliance with applicable drawings or specifications.

## INSTRUCTION

### 5. Requirements

- 5.1 General. The following modifications to a printed wiring, multilayer, or multiwire assembly are for the purpose of changing its original function or operation as a result of an engineering change. The modifications are applicable to single- or double-sided printed wiring, multilayer, or multiwire assemblies.

Electrostatic sensitive devices. Printed wiring assemblies containing ESDS devices shall be handled as defined in [LMS 4-3](#).

- 5.2 All modifications to a printed wiring, multilayer, or multiwire assembly shall be accomplished in a manner that will not degrade the quality or performance of the assembly. All modifications shall conform to [LMS 4-1](#), and all soldering to [LMS 11-3](#).
- 5.3 Conductor spacing. Modifications shall not reduce the conductor spacing to less than that provided by the original design. The cross-sectional area of wires, leads, or copper strips shall be equal to or larger than the replaced conductor.
- 5.4 Conductor modification. If possible, all conductors that are cut shall have a minimum of the width of the copper conductor removed. The cut should also be made at least .010 inch (0.25 mm) from land areas or circuit junctions where conductors are greater than .010 inch (0.25 mm) in width. For conductors equal to or less than .010 inch (0.25 mm), a minimum of .005 inch (0.13 mm) is required. (See Figure 1).

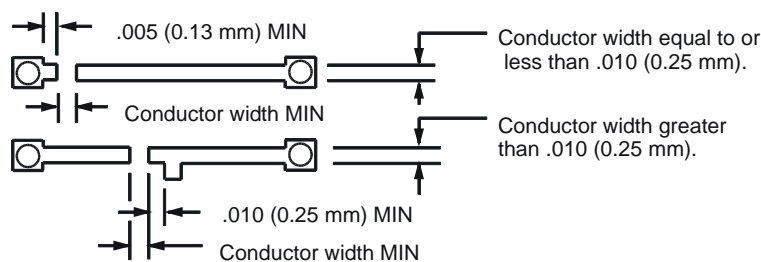

00102510

**Figure 1 Conductor Modification**

- 5.5 The affected area of all conductors that are modified, as shown in Figure 1, shall be covered with conformal coating as specified in [LMS 4-1](#) or an epoxy

adhesive. The epoxy adhesive is also required where wire jumpers are attached to conductors. Recommended adhesive is Link PN 255413.

- 5.6 Adding traces. Conductors may be connected together using wire jumpers as defined in paragraph 1.7 or by adding a copper foil trace as defined below:
- a. Remove a section of copper conductor, equal in width and thickness of the conductors to be connected together, from a scrap board.
  - b. Clean the board surface area, where a trace is to be added, with isopropyl alcohol or other approved solvent and allow to dry.
  - c. The added trace must overlap the conductors being connected together by a minimum of .125 inch (0.318 cm). The overlapped area must first be cleaned of all contamination by an abrasive means. Finish cleaning the area with isopropyl alcohol or other approved solvent.
  - d. Place the copper foil in place and lap solder each end.
  - e. Remove the solder flux and bond the added copper foil to the board with an epoxy adhesive.
- 5.7 Wire.
- a. Jumper wires longer than .50 inch (12.7 mm) shall be insulated. Bus wires .50 inch (12.7 mm) or shorter may be solid copper bus wire.
  - b. Added wires. Wires used for connecting two conductors together should be soldered a minimum distance of .050 inch (1.27 mm) from land areas as shown in Figure 2.

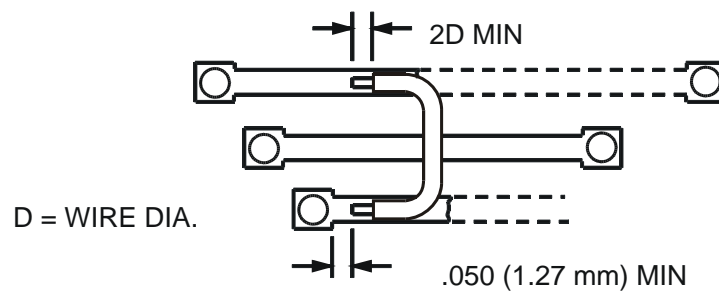

00102511

**Figure 2 Connecting Two Conductors**

- c. A maximum of two wires may be attached to any termination. Recommended methods of attaching wires to DIP ICs are shown in Figure 3.

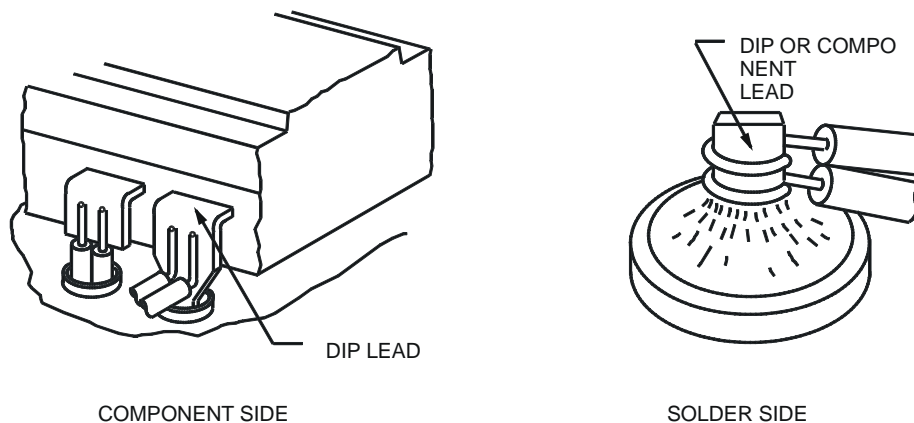

00102512

**Figure 3 Wire Connections to DIP**

- d. Wire routing. Wires should be routed in the X and Y directions, by the shortest practical route and minimizing wire crossings unless otherwise specified by the modification instruction. Added wires shall not cover plated-through component mounting holes. Wire routings on boards having the same part number shall be routed the same.

- e. Preferred termination. Wires shall be connected at a point where heating to remove an adjacent component will not cause the wire to become unsoldered. Unused through holes are the preferred termination for wires.
  - f. Securing of wires. Wires shall be secured to the board except where they pass through pin fields or where a 1.0 inch (25.4 mm) or shorter wire has both ends terminated in plated-through holes.
  - g. Existing terminals. If the assemblies have been conformally coated, wires or leads added to the existing terminals shall be attached above the conformal coated area or the conformal coating shall be removed prior to attachment.
- 5.8 Eyelets and terminals. Eyelets and terminals specified in the modification instructions shall be installed in accordance with [LMS 4-1](#).